

nano One

Resin portfolio for
demanding applications



Perfect resins for demanding applications

UpNano is a technology leader in the development and manufacture of high-resolution 3D printing systems based on 2-photon polymerization (2PP). The commitment to offering customers a holistic solution is reflected in the product portfolio, which comprises 2-photon resins in addition to hardware and software.

Matching resins for every application

The product portfolio of photosensitive polymer resins is optimized to utilize the full potential of the ultrafast NanoOne systems. It includes nine resins, each with special properties for specific applications – from performance printing resins to opto-transparent resins for optical and microfluidic applications to biocompatible formulations tested for in-vitro cytotoxicity according to EN ISO 10993-5:2009.



Optimized for the highest performance

Resins that are made to realize 2PP rapid prototyping and batch production of micro components with exceptional speed and high throughput.

Open material platform

The NanoOne platform is an open material platform. In addition to the UpNano photo resins and partner materials from BIO INX® or Glassomer, commercially available third-party materials or customer materials can also be used.

Standard
production



upphoto

Optically
transparent



upopto

High-resolution
applications



upbrix



updraft



upflow



upsol

Special
applications



upblack



upthermo



upquartz

Meeting specific requirements

Additionally, to meet customer-specific requirements, UpNano also offers material adaptations and proprietary material development to assist in realizing the desired property profiles of specific applications.

nanoOne

Upscale nanofabrication

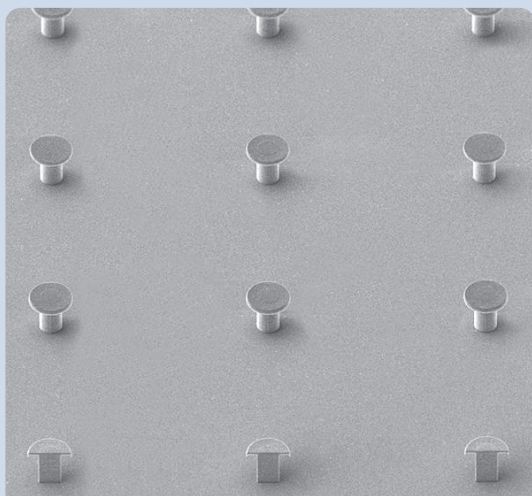
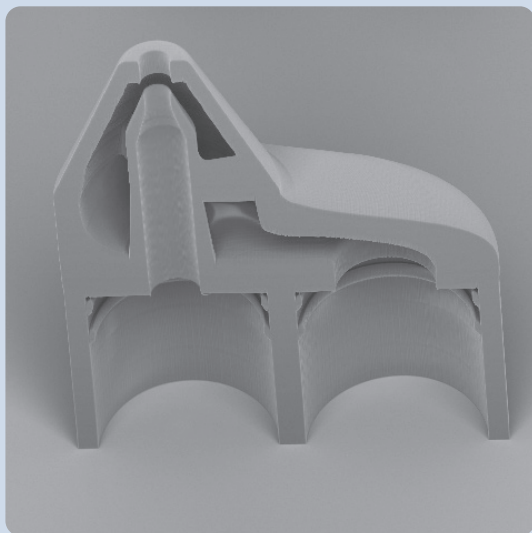
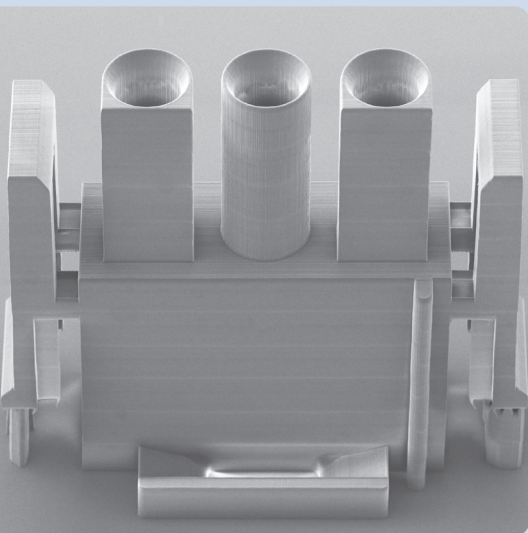

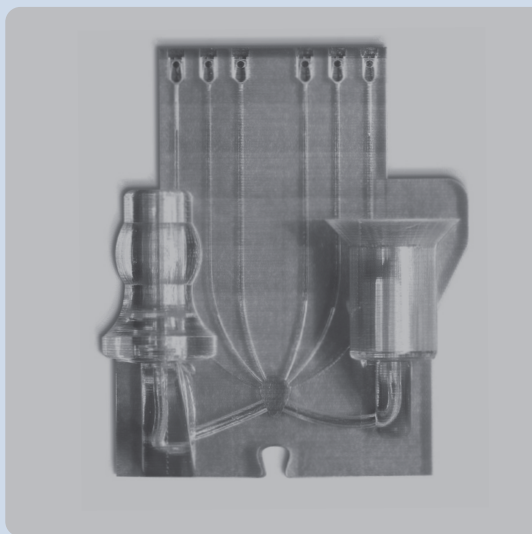
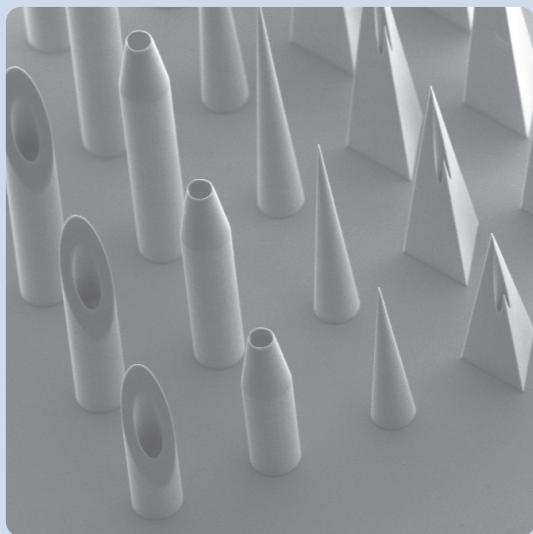
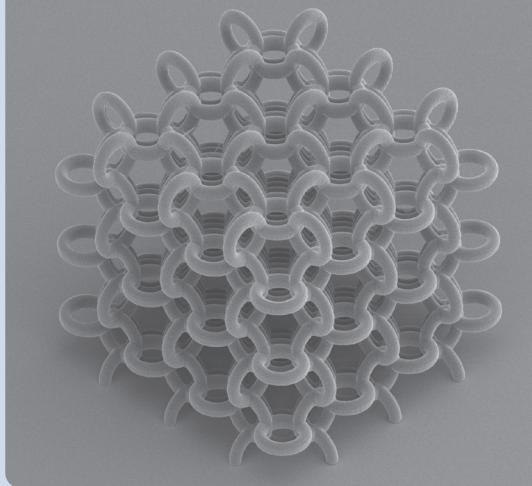
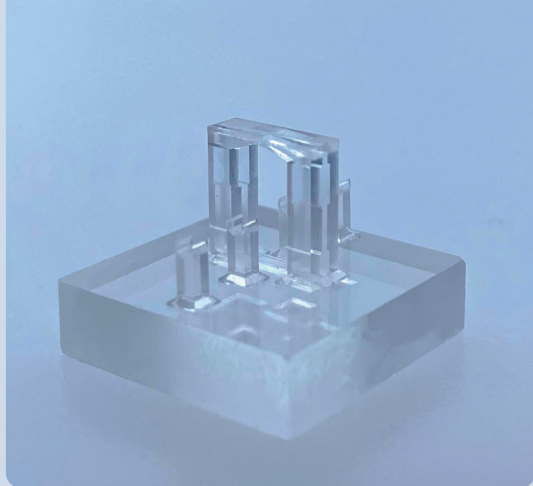

Scientific breakthroughs
of renowned institutes
with the NanoOne

Publications



A print job just a few clicks away

Parameter profiles for all objective and material combinations are defined in the Think3D data-preparation software. This enables the user to start a new project on the NanoOne in an intuitive and fast way. The customer can either rely completely on the proven and established presets or use them as a starting point for establishing a new process.



Dispensing, the clean and precise way

The UpNano resin portfolio is supplied in light-proof and practical resealable cartridges. With the help of manual or automatic dispensing systems, the material can be dispensed into the material vat, on a wafer or substrate with high precision and without bubbles or dripping.



- Drip-free material application
- No bubble formation
- Easy handling
- Light-protected, resealable packaging

“With the UpNano material portfolio, we cover the requirements of the most diverse application areas, while maintaining the highest precision and achieving industry-unique speed!”



Markus Lunzer, UpNano Team Lead Application and Material Development



High-performance 2-photon resin

The high-performance standard resin for functional components which are fully cured directly after 3D printing and require no thermal or optical post-processing. The polymerized parts are autoclavable and non-cytotoxic, certified according to EN ISO 10993-5:2009.

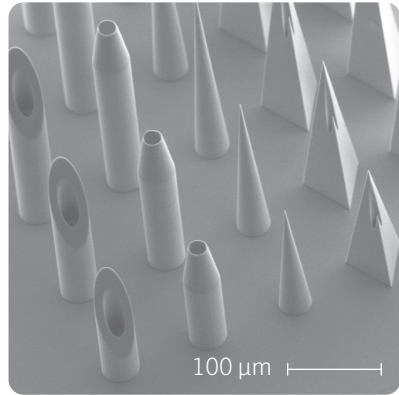

Elastic modulus	2,800 MPa
Tensile strength	85 MPa
Elongation at failure	12%
Flexural modulus	2,900 MPa
Flexural strength at 3.5%	127 MPa
Density	1.21 g/cm ³
Hardness	85 shore D
HDT A at 1.8 MPa	84°C
Dielectric constant <1 MHz	2.85
Refractive index at 589 nm	1.512

The transmission spectrum of UpPhoto was measured through a 200 μm thick, fully polymerized test specimen. High transmission in the NIR spectral region. Allows telecom applications.

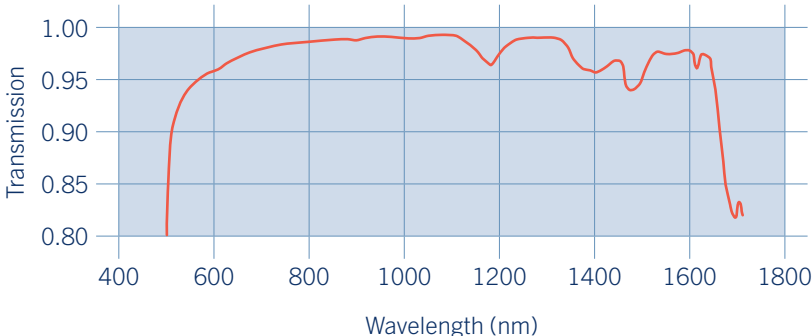
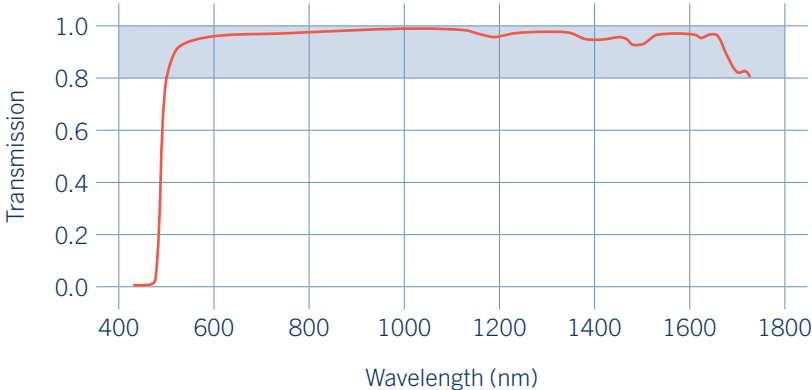



Fast prototyping 2-photon resin

The resin, which is optimized for throughput, is ideal for producing initial prototypes. The chemical reactivity of the resin allows for increasing of layer spacing and thus enables ultrafast 3D printing of microparts. UpDraft is tolerant to print parameter variations, enabling fast development cycles.

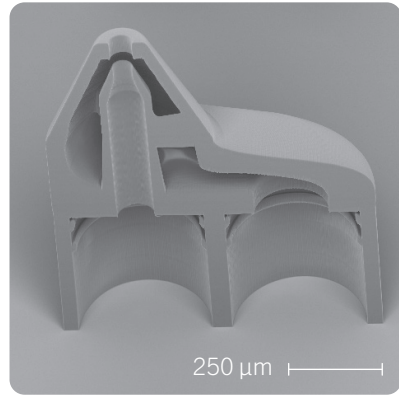

Elastic modulus	3,100 MPa
Tensile strength	80 MPa
Elongation at failure	4%
Flexural modulus	3,280 MPa
Flexural strength at 3.5%	95 MPa
Density	1.22 g/cm ³
Hardness	86 shore D
HDT A at 1.8 MPa	70°C



Low-viscosity and low-fluorescent 2-photon resin

The optical transparency and low viscosity make the resin ideal for printing microfluidics with channels smaller than 50 μm . In addition, the resin exhibits low autofluorescence and the material is certified as non-cytotoxic, according to EN ISO 10993-5:2009. UpFlow obtains its final properties after a UV post-curing step.

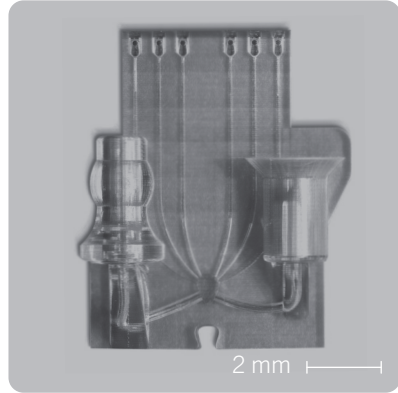

Elastic modulus	2,800 MPa
Tensile strength	85 MPa
Elongation at failure	12%
Flexural modulus	2,900 MPa
Flexural strength at 3.5%	127 MPa
Density	1.21 g/cm ³
Hardness	85 shore D
HDT A at 1.8 MPa	84°C



Ultralow-fluorescent 2-photon resin

The resin features high optical transparency. Unlike standard 2PP resins, it has ultralow autofluorescence and transmission down to the 350 nm range. The material is non-cytotoxic, certified according to EN ISO 10993-5:2009. UpOpto obtains its final properties after a UV post-curing step.

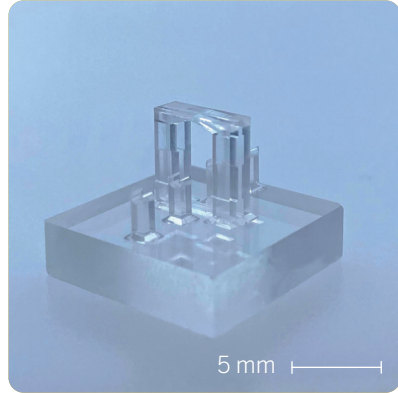

Elastic modulus	3,100 MPa
Tensile strength	80 MPa
Elongation at failure	4%
Flexural modulus	3,280 MPa
Flexural strength at 3.5%	95 MPa
Density	1.22 g/cm ³
Hardness	86 shore D
HDT A at 1.8 MPa	70°C
Refractive index at 589 nm	1.512

The transmission spectrum of UpOpto was measured through a 200 μm thick test specimen, both in green state and after UV post-curing. High transmission in the VIS and NIR spectral region.

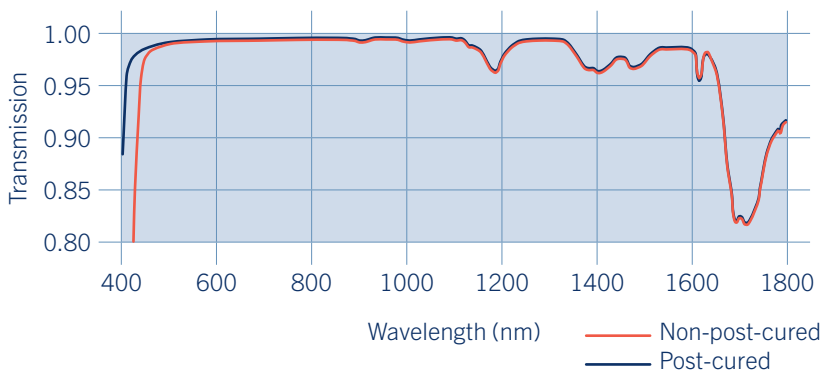
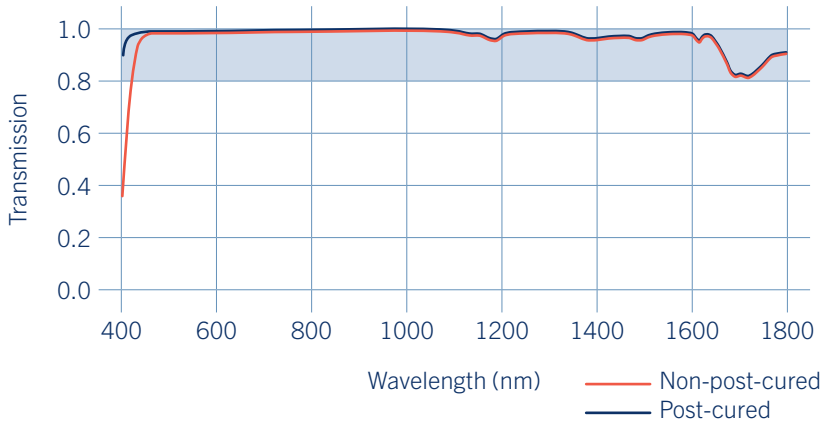



Refractive index-matched 2-photon resin

The refractive index of the material is matched to the immersion oil of high NA objectives and high cross-linking. It is used for ultrahigh-resolution applications and ideal for the fabrication of 2.5D patterns as well as structural details in the micro- and nanometer range.

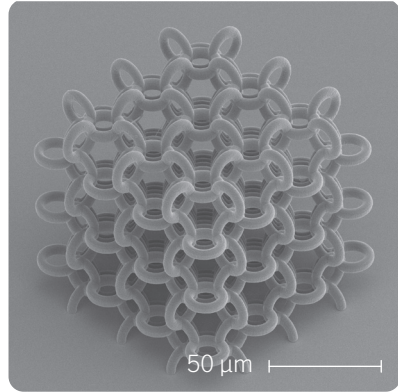

Elastic modulus	3,160 MPa
Tensile strength	62 MPa
Elongation at failure	2.3%
Flexural modulus	3,000 MPa
Flexural strength at 3.5%	103 MPa
Density	1.26 g/cm ³
Hardness	85 shore D



Low-transmissive 2-photon resin

The visually black and non-transparent resin for 2PP printing is a real masterpiece. The material has light blocking properties in the UV and VIS spectral range. Yet, the material is transparent to NIR and IR radiation, enabling the printing of fine details. The resin is non-cytotoxic, certified according to EN ISO 10993-5:2009.

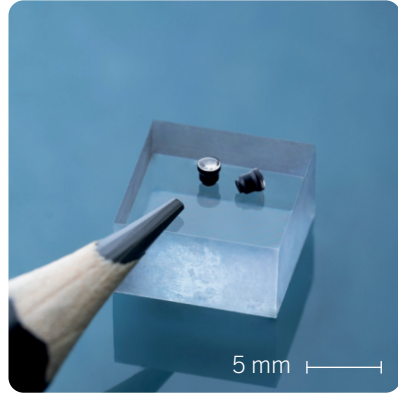

Elastic modulus	3,100 MPa
Tensile strength	80 MPa
Elongation at failure	4%
Flexural modulus	3,280 MPa
Flexural strength at 3.5%	95 MPa
Density	1.22 g/cm ³
Hardness	86 shore D
HDT A at 1.8 MPa	70°C



UPthermo

High-temperature 2-photon resin

Developed in cooperation with Cubicure, this resin has an exceptionally high heat deflection temperature HDT-B of greater than 300° C. Paired with high mechanical stiffness, it is ideal for static high temperature applications. The resin is non-cytotoxic, certified according to EN ISO 10993-5:2009.

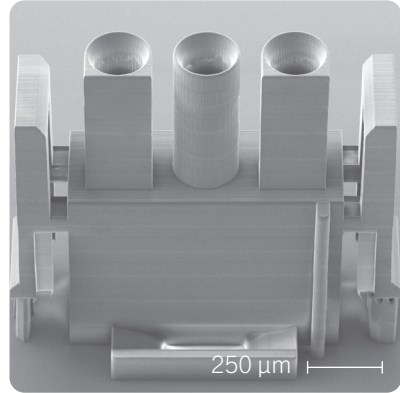

Elastic modulus	4,200 MPa
Tensile strength	60 MPa
Elongation at failure	1.4%
Flexural modulus	4,200 MPa
Flexural strength at 3.5%	190 MPa
Deflection at break	4.7%
Hardness	90 shore D
HDT A at 1.8 MPa	>180°C
HDT B at 0.45 MPa	>300°C

UpThermo was co-developed by UpNano and Cubicure. It is the first heat- and impact-resistant 2PP printing material on the market.

The proprietary Hot Lithography® technology, which has been successfully integrated into the NanoOne printing systems, enables the printing of the highly viscous material in the standard high 2PP quality and resolution. UpThermo impresses with its HDT-B of over 300°C and other exceptional properties.

2PP Hot Lithography®

UpNano has licensed the patented Hot Lithography® technology and adapted it to the 2PP process of the NanoOne platform in close cooperation with Cubicure. The aim was to establish Hot Lithography® as a retrofittable module to be able to equip all NanoOne printers. In addition to the hardware adaptation of Hot Lithography® for 2PP printing, the cooperation focused on the development of a material with special characteristics.

In material development, Cubicure's know-how in tailoring the molecular weight, functionality, and chemical nature of the resins complemented the photochemical know-how of UpNano. This was the basis for the joint development of UpThermo and its establishment as a standard material on the NanoOne printing systems.

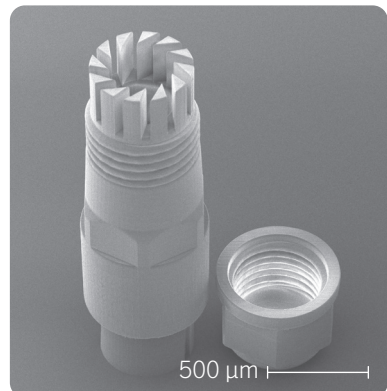



UPquartz

2-photon silica slurry

UpNano has developed a nanocomposite slurry for manufacturing fused silica (SiO_2) parts using 2-photon polymerization, in cooperation with Glassomer. Printed green parts are converted into fused silica by thermal debinding and sintering. After high-temperature treatment, the 2PP-processed parts exhibit the characteristic properties of fused silica glass.

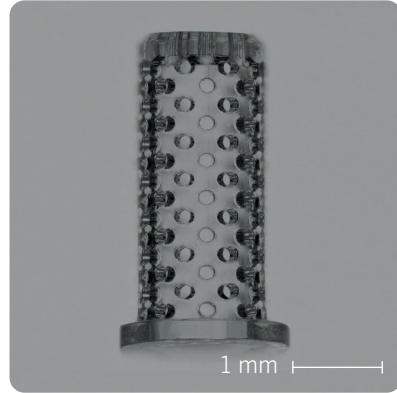

Bending strength	115 MPa
Density	2.2 g/cm ³
Vickers hardness	980 HV
Thermal expansion α_{30-500}	$0.56 \times 10^{-6} \text{ K}^{-1}$
Abbe number	67.8
Contact angle – H ₂ O	36°
UV transmission at 200 nm*	>84%
Refractive index at 589 nm	1.4589

* Sample thickness 1 mm

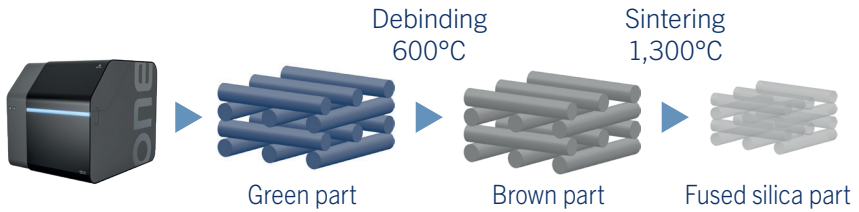

This specifically tailored 2PP material enables the production of SiO_2 parts with bulk volumes in the mm- and features in the μm -range. Leveraging the remarkable characteristics of fused silica, including its exceptional thermal and chemical resistance, superb mechanical properties, high optical transmission, and inertness, UpQuartz opens the door for applications in which polymers cannot be applied.

The material consists of dispersed SiO_2 nanoparticles in a polymerizable binder matrix. First, UpQuartz is 2PP printed to obtain the polymeric green part. Next, the green part is thermally debound at 600°C to remove the polymer matrix and subsequently sintered to fully dense fused silica at 1,300°C. During this process, the part undergoes isotropic shrinkage (28%) due to fusing of the SiO_2 particles.

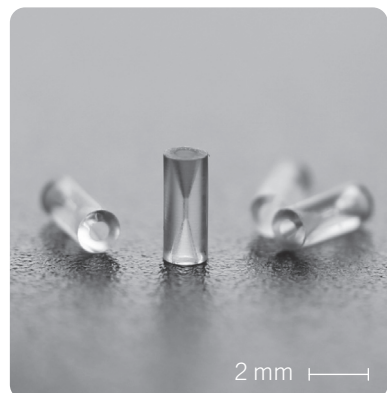
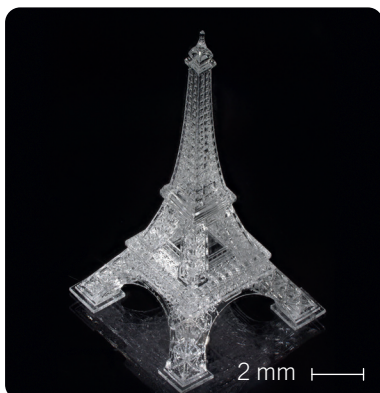



Sol-gel hybrid 2-photon resin

The negative thin-film resin can be applied to the intended substrate by spin-coating or drop-casting. During printing, the resin is gel-like and therefore allows the production of complex structures with overhangs and undercuts. Besides 2.5D and 3D microstructures, free-floating elements can also be printed.

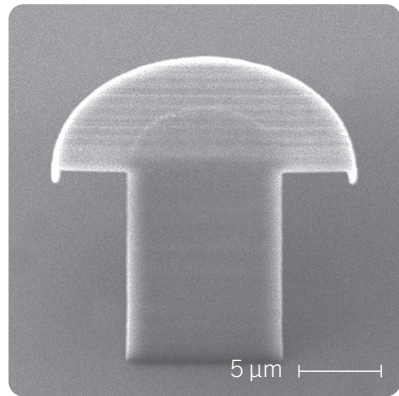
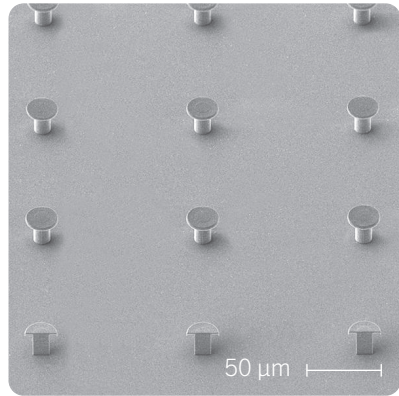

Print set-up

	Objectives	Print modes
	5x, 10x, 20x, 40x	Vat, bottom-up
	5x, 10x, 20x	Vat, bottom-up
	10x, 20x, 40x	Vat, bottom-up
	10x, 20x, 40x	Vat
	40x	Vat, bottom-up
	10x	Vat
	5x, 10x	Heated-vat
	5x, 10x	Vat
	20x, 40x	Top-down, bottom-up

Biocompatible printing resins according to EN ISO 10993-5

In addition to a cell-compatible process, the printing resin is a decisive factor. UpNano has a portfolio of five biocompatible resins certified as non-cytotoxic according to EN ISO 10993-5:2009.

Each of these resins, in addition to their biocompatibility, have distinct properties emphasizing the wide range of possible applications.

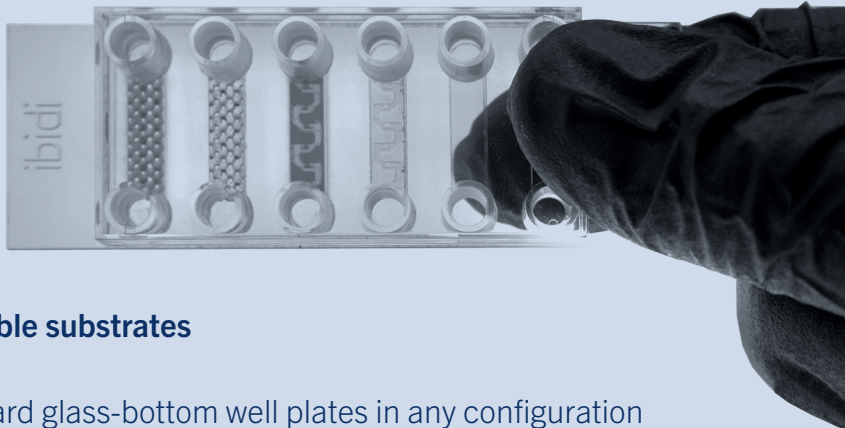

Compatible substrates

- Standard glass-bottom well plates in any configuration
- Glass-bottom petri dishes Ø 20–74 mm
- Glass-bottom μ slides and μ dishes in different formats
- Microfluidic chips commercially available or custom-made
- UpNano glass substrates and wafers
- Opaque and translucent wafers

BIO INX® – High-quality bioinks and biomaterials

Together with the Belgian company BIO INX®, we have established a material portfolio that is not only cell-compatible but also optimized for the NanoOne platform.

HYDROBIO  U200

Gelatin-based hydrogel resin

Cell interactive, gelatin type B-based hydrogel, derived from natural collagen. Unique two-component bioresin enabling printing in the presence of living cells with low autofluorescence. The crystal-clear material is suitable for light- and laser-scanning microscopy, biodegradable and non-cytotoxic (ISO 10993-5).

DEGRAD  U100

Polyester-based, biodegradable resin

Robust, biodegradable thin-film material (2–5 years), solid state cross-linking: suitable for both bottom-up and top-down printing. Extremely high resolution (<500 nm), supports overhangs, for cell seeding, non-cytotoxic (ISO 10993-5).

HYDROTECH  U100





Technical thin-film hydrogel

Bioinert, synthetic hydrogel material for bottom-up and top-down printing with high mechanical integrity. No structural deformation in aqueous medium, due to low water absorption capacity. Suitable for cell seeding, non-cytotoxic (ISO 10993-5).

HYDROTECH  U200

Synthetic, technical hydrogel

Bioinert, mechanically robust, soft and flexible hydrogel resin. Orange-red viscous liquid, allowing for VAT mode or in-chip printing. White flexible solid after development in dry state. Opaque when swollen in water. SEM imaging compatible because of its drying and rehydrating properties. Suitable for cell seeding, non-degradable, non-cytotoxic (ISO 10993-5).

	Young's Modulus	Volumetric swelling ratio
HYDROBIO  U200		1.2–2.1
DEGRAD  U100	50–60 MPa	
HYDROTECH  U100	30–40 MPa	1.2–2.1
HYDROTECH  U200	3–4 MPa	1.2–1.7

Co-operation with BIO INX®

BIO INX® – a spin-off company of Ghent University and Vrije Universiteit Brussel – focuses on the commercialization of materials and bio-inks for 3D bioprinting or biofabrication. For product development and establishment, the team relies, among other technologies, on a NanoOne bio system.

The integrated incubation system is essential and important for their work. The HYDROBIO INX U200 is the first hydrogel for use together with living cells and 2-photon polymerization that is also crystal clear for light-microscope use, a very important factor many researchers.

Many years of research work by the team have already resulted in a remarkable material portfolio. With a diverse range of material properties, the applications become nearly limitless: the bioinks can be applied for various tissue types with applications in regenerative medicine as well as drug and cosmetics screening and bioengineering.

Elongation at break	Objectives	Print modes
	5x, 10x, 20x	Bottom-up, top-down
20–30%	20x, 40x	Bottom-up, top-down
	20x, 40x	Bottom-up, top-down
	10x, 20x, 40x	Vat, bottom-up



Download brochure



+43 (0)1 890 16 52 | office@upnano.com | www.upnano.com
© 2024 UpNano GmbH, Modecenterstrasse 22/D36, 1030 Vienna, Austria

Follow us on

